

*면치 하지 마시오.

NOTE

- 1.가공후 진공열처리 내경+0.3~+0.4 외경+0.1~+0.2
- 2.진공열처리후 내경 1차연마 내경+0.09
- 3.1차연마후 가스질화열처리
- 4.가스질화 열처리후 2차연마
- 5.입고

SKD60
 Ø100x215-2EA

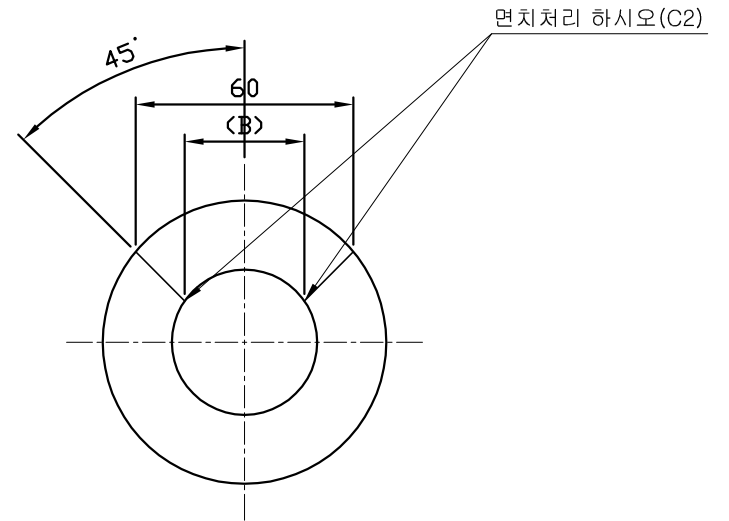

		SKD61	1EA		
NO.	PARTS NAME	MAT'L	Q'TY	SIZE	REMARKS
MACHINE 100TON COLD CHAMBER DIE CASTING M/C					
PARTS DWG					
PARTS NO		PARTS NAME Plunger sleeve			
DGN	PCJ	CHK	APP	DATE 2006.1.5	SCALE 1 / 1